

# SUN SHINE 38

Designer Tony CASTRO

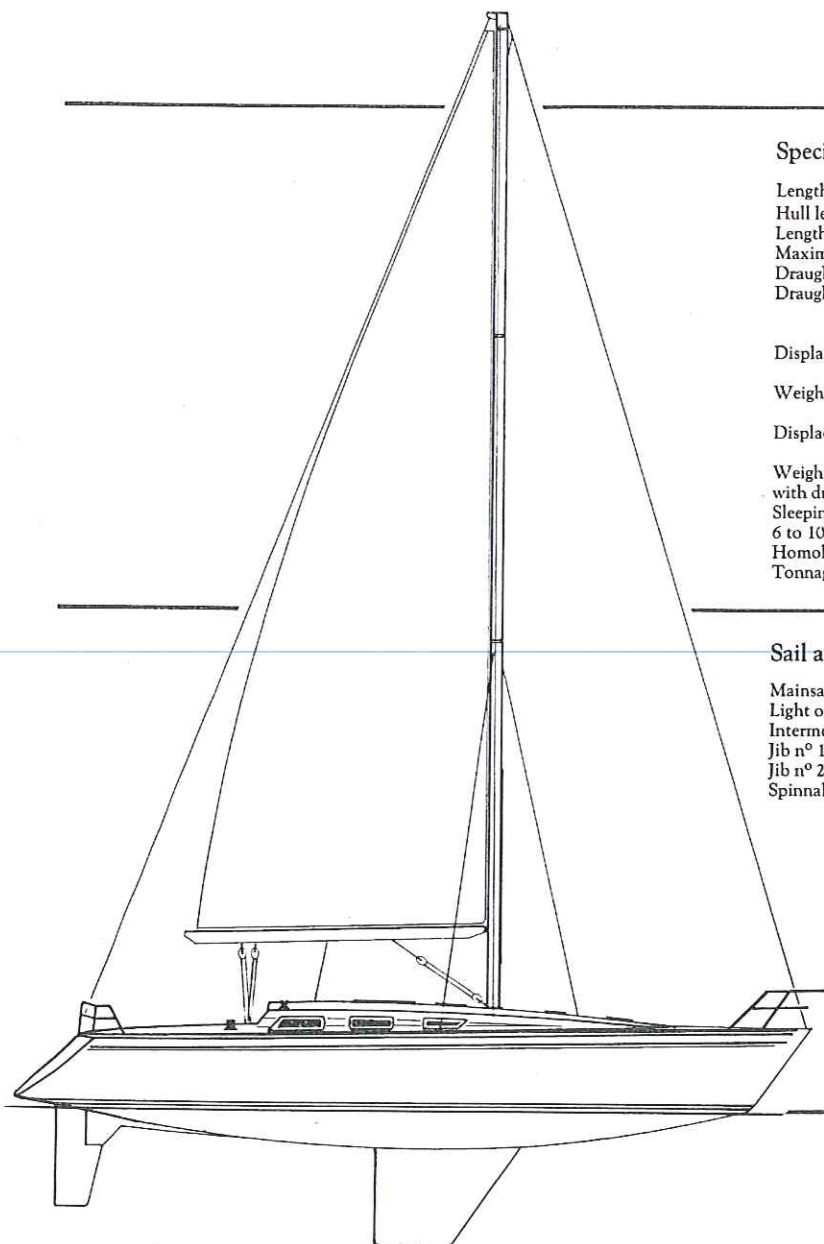

## Specifications

Length over all	: 11.65 m (38'2.5")
Hull length	: 11.20 m (36'9")
Length on waterline L.W.L.	: 9.35 m (30'8")
Maximum beam	: 3.85 m (12'7.5")
Draught F/K	: 1.90 m (6'3")
Draught L/K	: 1.24/2.10 m (4'1"/6'11") [deep/shoal]
Displacement F/K light	: 5400 kgs (11905 lbs approx.)
Weight F/K ballast	: 2280 kgs ( 5026 lbs approx.)
Displacement L/K light	: 5750 kgs (12677 lbs approx.)
Weight L/K ballast with drop keel	: 2620 kgs ( 5776 lbs approx.)
Sleeping accommodation :	6 to 10 people (according to version)
Homologation :	Class 1 - 8/9/10 people
Tonnage	: 12.16 register tons

## Sail area

Mainsail	: 28 m <sup>2</sup> ( 301 sq.ft.)
Light or medium genoa	: 48 m <sup>2</sup> ( 517 sq.ft.)
Intermediate	: 38 m <sup>2</sup> ( 409 sq.ft.)
Jib n° 1	: 28 m <sup>2</sup> ( 301 sq.ft.)
Jib n° 2	: 20 m <sup>2</sup> ( 215 sq.ft.)
Spinnaker	: 107 m <sup>2</sup> (1152 sq.ft.)

 **Jeanneau**

# SUN SHINE 38

TEAM VERSION

## Forward cabin

Double berth  
2.00 m × 1.68 m (6'6.5" × 5'6")  
Mattress with removable fabric covers  
Mattress thickness 10 cms (4")  
Lateral shelving to port and starboard  
(2.00 m × 0.15 m / 6'6.5" × 6")  
Stowage lockers, compartmented, beneath berth  
Opening deck hatch  
(0.38 m × 0.50 m / 1'3" × 1'8")  
Night blind  
Double-intensity dome ceiling light  
Thru-deck vent giving continual ventilation

Headlining, light-coloured, colour-fast, rotproof  
Carpetting on sole  
Space-making removable bedhead  
Louvred air vent at foot of door  
Headroom 1.75 m (5'9")

## Head/washroom

Laminated teak-lined unit  
Washbasin with shower-head attachment, by foot pump  
Storage space over and under wash-basin unit  
Thru-deck vent giving continual ventilation  
Opening deck port  
(0.33 m × 0.20 m / 1'1" × 8")  
Double-intensity dome ceiling light  
Manual shower drainage pump, beneath washbasin  
Wooden duckboarding over shower-basin inner liner

Full-length mirror  
12 V power socket  
Marine WC  
Sliding separating door with louvred air vent  
Clothes hook, towel rail, wash-glove hook  
Headroom 1.75 m (5'9")

## Gangway

Separating door to forward cabin  
Separating door to head/washroom  
Spacious hanging locker to starboard  
Opening deck port  
(0.33 m × 0.20 m / 1'1" × 8")

## Saloon

Body-contoured backrests and seating  
Fabric-covered backrests and seating  
Seating thickness 10 cms (4")  
Settee backrests lift up to form pilot berths  
Stowage behind backrests  
Shelving running above backrests along the hull - Bar  
L-settee to port with short arm across forward bulkhead  
Bar built into saloon-hanging locker bulkhead  
Opening port  
(0.38 m × 0.50 m / 1'3" × 1'8")  
Night blind

Roof ports with drapes/curtains  
Striplight over table  
Grabrail along ceiling above roof ports  
2-leaf table with fiddle  
2 fresh-water tanks beneath saloon settees and stowage space  
Teak headlining  
Teak surround to roof ports  
Drop keel raising winch beneath central section of table (L/K version)  
Teak floorboarded sole  
Dustbin  
Headroom 1.83 m-1.75 m (6' × 5'9")

## Navigation station

Chart table 1.06 m × 0.68 m (3'6" × 2'3")  
Chart reading light  
Dome ceiling light  
Large panel to house navigational equipment  
Cubby-holes  
Library shelving  
Locker beneath seat  
Bilge pump in locker under table also acts as oilskins locker  
Stainless steel fuel tank beneath table with shut-off cock  
Navigator seat is shaped and teak batted  
Grabrail

## Electrics panel

Illuminated visualisation of the different electrics on the boat  
11 thermostatic circuit-breakers  
Load tester for the two batteries  
3 battery cut-offs at the foot (to port) of the companionway  
8 switches covering each electrical function  
2 batteries with an electronic load dispatcher

## Galley

Functional L-shaped arrangement of units  
Double-sink (stainless steel)  
0.24 m × 0.34 m (9.5" × 1'1.5")  
Fresh water by pressure pump  
Sea water, by foot pump, separate system  
3 drawers under starboard sink under roof screen  
Storage lockers beneath sink unit (port) with waste-bin, shelving, cocks  
Compartment ice-box with inner basket  
60 mm thick injected polyurethane foam insulation  
2-burner cooker with oven (incorporating safety device), gimballed, with lock

## Grabrail

Wooden protective grabrail along front of cooker  
Grabrail on ceiling above port  
Crockery locker and storage lockers above cooker and ice-box  
Crockery : 8 plates, 8 dishes, 8 goblets, 8 bowls  
Cutlery : 8 knives, 8 forks, 8 teaspoons, 8 dessert spoons. Cutlery tray  
Galley unit features full-length fiddle  
Teak floorboarded sole  
Headroom 1.80 m (5'11")

---

### Cockpit locker starboard aft quarter

Compartmented locker comprising  
Stowage for gas bottle with vent  
Cubby-hole  
Section for hot water tank (owner's version)

### Cockpit locker port aft quarter

Spacious locker for common sailing items  
Stowage space for companionway hatch  
(owner's version)

### Liferaft locker beneath helmsman's seat

### Teak battened cockpit

Cubby-holes for winch handles built into the cockpit seat backrests  
Every locker is lockable

---

### Headroom

#### Team version

Forward cabin	1.75 m (5'9")
Washroom/head	1.75 m (5'9")
Gangway	1.75 m (5'9")
Saloon	1.83 m/1.75 m (6'/5'9")
Companionway	1.86 m (6'1")
Galley and Navigation station	1.80 m (5'11")
Aft cabins	1.80 m (5'11")

#### Owner's version

Forward cabin	1.75 m (5'9")
Saloon	1.83 m/1.75 m (6'/5'9")
Galley	1.80 m (5'11")
Companionway	1.86 m (6'1")
Washroom/head	1.80 m (5'11")
Aft cabin	1.80 m (5'11")

---

### Capacities

#### Team version

Non-rigid water tanks	2 × 100 L. (2 × 22 imp.galls/2 × 26.42 US galls)
Diesel	85 L. (18.69 imp.galls/22.45 US galls)
Inboard battery	70 A/H
Engine battery	70 A/H
Ice-box	100 L. (3.5 cu.ft.)
Alternator power	55 A/H
3 GM Yanmar	

#### Owner's version

Stainless steel water tank	2 × 100 L. (2 × 22 imp.galls/2 × 26.42 US galls)
Diesel	85 L. (18.69 imp.galls/22.45 US galls)
Inboard battery	70 A/H
Engine battery	70 A/H
Ice-box	100 L (3.5 cu.ft.)
Alternator power	55 A/H
3 GM Yanmar	
Hot water tank (optional)	43 L. (9.45 imp.galls/11.36 US galls)

---

### Spinnaker fittings (optional)

Halyards with stainless steel swift snap  
shackle and swivel  
Sheets with stainless steel swift snap shackle  
and swivel  
Downhaul with stainless steel swift snap  
shackle and swivel  
Topping lift with stainless steel swift snap  
shackle and swivel  
Anodised aluminium spinnaker pole  
2 × 2-speed spinnaker sheet winches  
Spinnaker sheet return block

---

# SUN SHINE 38

DECK LAYOUT - TEAM AND OWNER'S

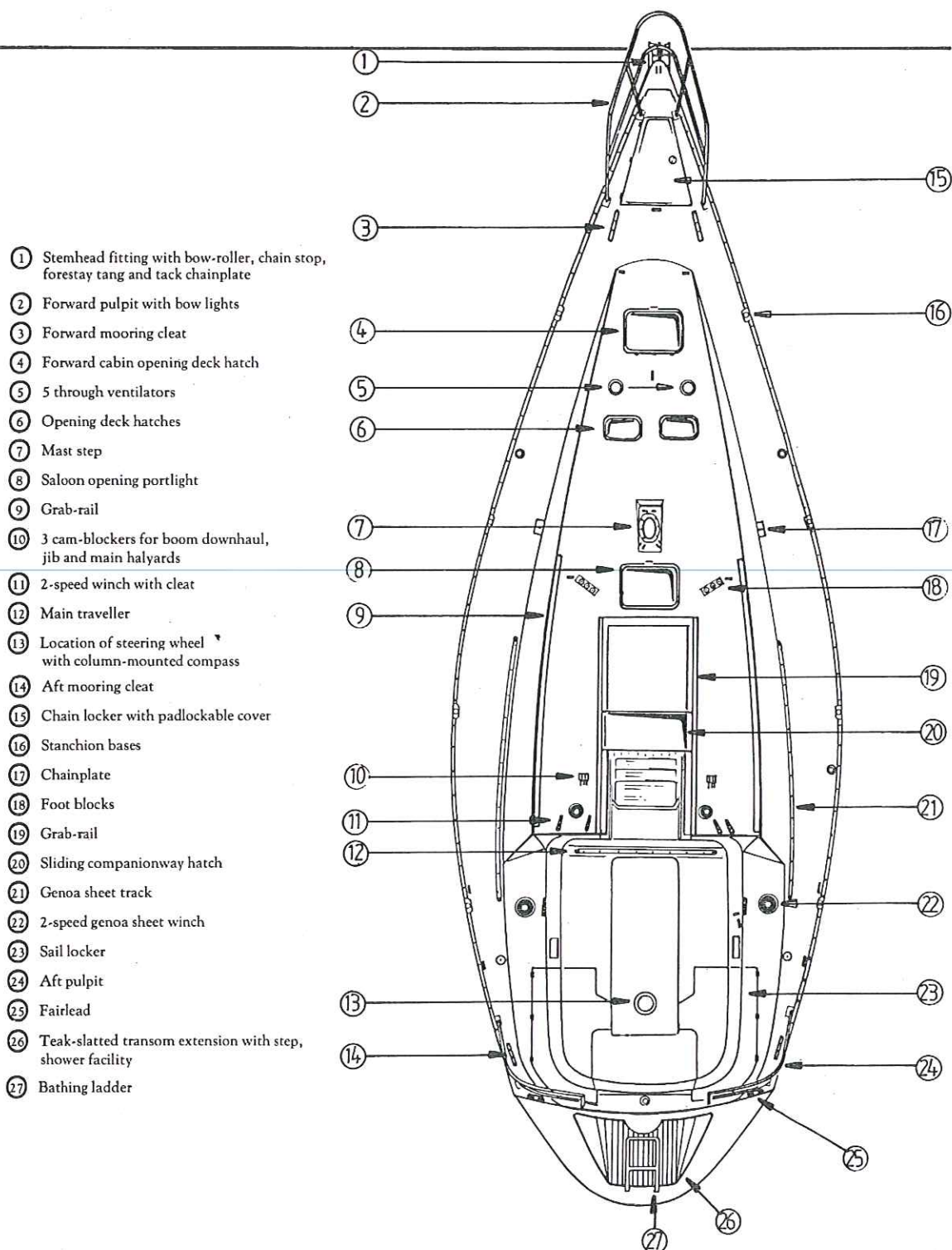



## Companionway

Companionway hatch in two parts  
 Sliding deck hatch made of Altuglass  
 Rubber sealing strip  
 4 companionway steps with non-slip pads and foot holds  
 2 grabrails down companionway steps  
 Stowage space for small equipment at the height of the first step  
 Engine extinguisher in this stowage space  
 3 last steps are hinged allowing access to engine compartment  
 Battery cut-offs at the foot of the companionway steps (portside)

Black plug removable in case of fire (extinguisher nozzle entry)  
 Headroom 1.86 m (6'1")

## Aft quarter cabins (port and starboard)

Double berth (port)  
 1.95 m × 1.50 m (6'5" × 4'11")  
 Double berth (starboard)  
 1.95 m × 1.55 m (6'5" × 5'1")  
 Mattresses with removable fabric covers  
 Mattress thickness 10 cms (4")  
 Stowage lockers, compartmented, beneath berths  
 Double intensity dome ceiling light  
 Hanging locker  
 Lateral shelving along bed (hull-side)  
 1.20 m × 0.25 m (3'11" × 10")

Roof port with drape/curtain  
 Opening deck port to cockpit  
 0.10 m × 0.32 m (4" × 1'5")  
 Louvred air vent at foot of door  
 Headlining, light coloured, colour-fast, rotproof  
 Carpetting on sole  
 Continual ventilation by vent to outside  
 Access to stuffing-box beneath aft berth (starboard)  
 Headroom 1.80 m (5'11")

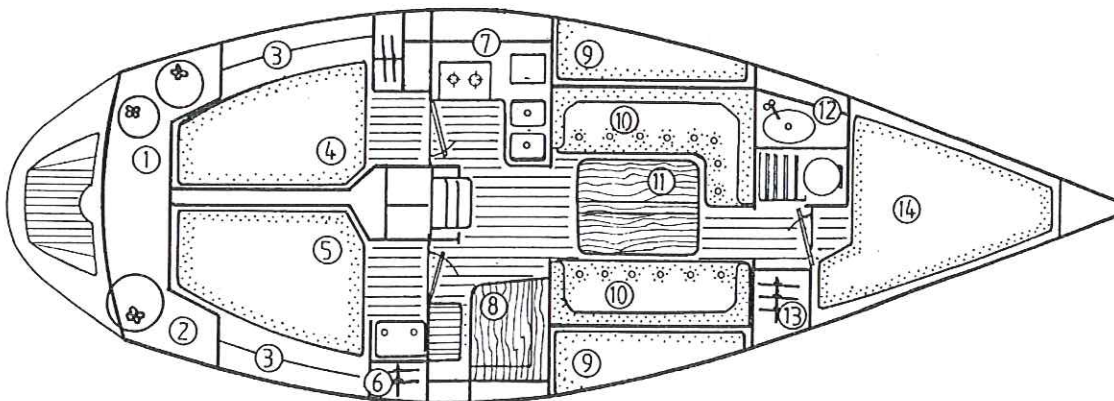

- |                             |                      |                       |
|-----------------------------|----------------------|-----------------------|
| ① Sail-stowage lockers      | ⑥ Hanging locker     | ⑪ Saloon table        |
| ② Sail-stowage lockers      | ⑦ Galley             | ⑫ Washroom-head       |
| ③ Aft cabin stowage shelves | ⑧ Navigation station | ⑬ Hanging locker      |
| ④ Aft cabin berth           | ⑨ Upper bunk berths  | ⑭ Forward cabin berth |
| ⑤ Aft cabin berth           | ⑩ Saloon             |                       |

---

# SUN SHINE 38

OWNER'S VERSION

---

## Forward cabin

Double berth 1.90 m × 1.68 m (6'3" × 5'6") Mattress with removable fabric covers Mattress thickness 10 cms (4") Removable bedhead forms seat Storage at foot of bed Lateral shelving to port and starboard 1.90 m × 0.15 m (6'3" × 6") Stowage lockers, compartmented, beneath berth Opening deck hatch 0.38 m × 0.50 m (1'3" 1'8") Night blind Dome ceiling light	Directable spot at bedhead Headlining, light-coloured, colour-fast, rotproof Locker with shelving and hanging locker Washbasin with pressurised hot and cold water tap (Vanity) Hot water optional Storage space over and under washbasin unit Mirror on door of storage over washbasin 2 thru-deck vents giving continual ventilation Louvred air vent at foot of door Carpetting on sole Headroom 1.75 m (5'9")
--	---

---

## Saloon

Body-contoured settee with rounded angles Port settee with short arm across saloon-forward cabin bulkhead Stowage behind backrests Shelving running above backrests along the hull 2 opening deck ports 0.33 m × 0.20 m (1'1" × 8") 1 opening port 0.38 m × 0.50 m (1'3" × 1'8") Night blind Roof ports with drapes/curtains Drape/curtain rods built in under moulding	Grabrails below starboard roof port 2 dome ceiling lights 1 built-in striplight with switch on chart table fiddle 2-leaf table with fiddle French-style bread-bin under central section of table Bar in central section of table Handholds separating bulkheads between saloon, galley and navigation station 2 stainless steel fresh water tanks beneath settee and stowage space Hullining of grooved teak	Crumb-tray in sole Teak surround to roof ports Teak floorboarded sole Headlining of teak and fabric (light coloured, colour-fast, rotproof) In ceiling : wires conduit between mast and forward cabin bulkhead concealed behind removable teak panel Teak lined mast pillar Drop keel raising winch beneath central section of table (L/K version) Headroom 1.83 m × 1.75 m (6' × 5'9")
---	--	--

---

## Navigation station

Chart table 0.87 m × 0.73 m (2'10" × 2'5")  
Directable chart reading light  
Dome ceiling light  
Large panel to house navigational equipment  
Cubby-hole  
Library shelving  
Stainless steel diesel tank with shut-off cock beneath table  
Bilge pump in locker under table  
Locker under seat  
Roof ports with drape/curtain  
Drape/curtain rods built in under moulding  
Grabrail below port  
Navigator seat is shaped and teak battened

## Electrics panel

Panel fixed onto hinged door  
Visualisation of the different electrics on the boat  
11 thermostatic circuit-breakers  
8 switches covering each electrical function  
Load tester for the two batteries  
3 battery cut-offs beneath last companionway step  
Fill check for the two water tanks  
2 batteries with an electronic load dispatcher

## Galley

Functional L-shaped arrangement of units 4 pantry drawers in short arm of galley Double-sink (stainless steel) 0.23 m × 0.34 m and 0.30 m × 0.34 m (9" × 1'1.5" and 1' × 1'1.5") Pressurised hot and cold water tap (Hot water optional) Sea water and fresh water by foot pump Commodious storage locker beneath sink unit with waste-bin, shelving, cocks Compartmented ice-box with inner basket 60 mm thickness of injected polyurethane foam insulation	2-burner cooker with oven (incorporating safety device), gimballed, with lock Wooden protective grabrail along front of cooker Fold-down board to cover hob 12 V power socket (cigar lighter-type) Fiddle around galley work surfaces Crockery and storage lockers above cookers and ice-box Crockery : 8 plates, 8 dishes, 8 goblets, 8 bowls Cutlery : 8 knives, 8 forks, 8 teaspoons, 8 dessert spoons. Cutlery tray	Dome ceiling light Roof port with drape/curtain Drape/curtain rod built in under moulding Teak floorboarded sole Headroom 1.80 m (5'11")
--	--	--

---

### Companionway

Sliding deck hatch made of Altuglass  
 Rubber sealing strip  
 Companionway hatch in two parts with stowage in port locker aft  
 4 companionway steps with non-slip pads and footholds  
 Access hole for entry to extinguisher nozzle  
 2 grabrails down companionway steps  
 Child handholds down companionway uprights  
 Last two steps removable allowing access to engine compartment  
 Battery cut-offs under last step  
 Headroom 1.86 m (6'1")

### Washroom/Head

Washbasin with shower-head attachment to tap, hot and cold water (hot water optional)  
 Laminated teak-lined unit with fiddle  
 Storage space over washbasin  
 Storage space under washbasin with shelving  
 Mirror on door of upper storage  
 Full-length mirror on bulkhead  
 Spacious oilskins locker with drainage  
 Duckboard seat folds down onto toilet  
 Striplight over washbasin  
 Dome ceiling light  
 Roof port with drape/curtain  
 Drape/curtain rod built in under moulding

Opening port onto cockpit with drape/curtain 0.10 m × 0.32 m (4" × 1'5")  
 Towel rail  
 Hygienic paper holder inside door of oilskins locker  
 Clothes hook  
 Wash-glove hook  
 Shower drainage pump, manual, beneath washbasin  
 Wooden duckboarding over shower basin inner liner  
 Cocks beneath washbasin  
 Cigar lighter type 12 V power socket  
 Headroom 1.80 m (5'11")

### Aft cabin

Double berth  
 1.60 m × 1.93 m (5'3" × 6'4")  
 Mattress thickness 10 cms (4")  
 Compartmented locker beneath berth  
 Directable reading spotlight at bedhead  
 2 dome ceiling lights one of which is over the washbasin unit (vanity)  
 Washbasin with pressurised hot and cold water tap (hot water optional)  
 Storage space over washbasin  
 Storage space under washbasin with shelving  
 Mirror on door of upper storage  
 Hanging locker

Lateral shelving above bed (hull-side) 1.20 m × 0.20 m (3'11" × 8")  
 Large panel removes to reveal stowage space over engine  
 Roof port with drape/curtain  
 Drape/curtain built in under moulding  
 2 opening ports onto cockpit with drapes/curtains 0.10 m × 0.32 m (4" × 1'5")  
 Louvred air vent at foot of door  
 Headlining, light coloured, colour-fast, rotproof  
 Carpetting on sole  
 Access to stuffing-box  
 Access to the electric bilge pump  
 Headroom 1.80 m (5'11")

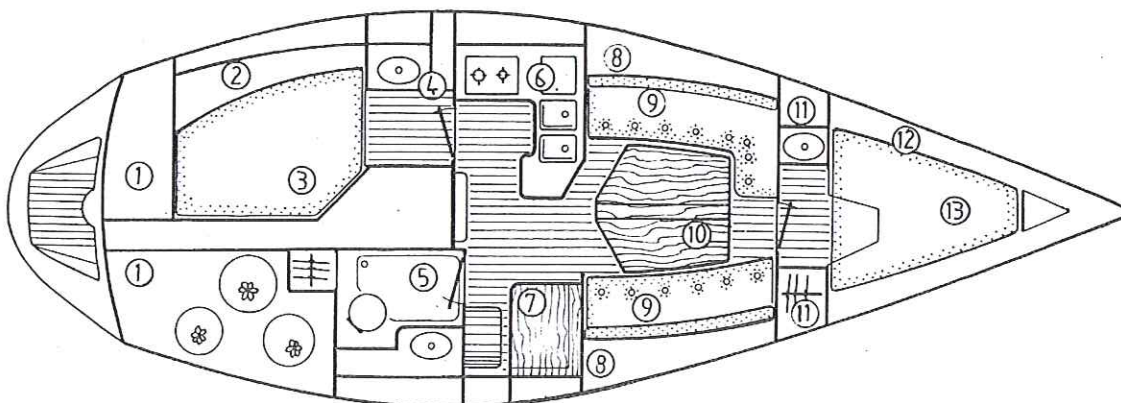

- |  |                      |  |
|--|----------------------|--|
| ① Sail-stowage locker                    | ⑥ Galley             | ⑩ Saloon table                               |
| ② Aft cabin storage shelves              | ⑦ Navigation station | ⑪ Forward cabin washbasin and hanging locker |
| ③ Aft cabin berth                        | ⑧ Stowage shelves    | ⑫ Forward cabin storage shelves              |
| ④ Aft cabin washbasin and hanging locker | ⑨ Saloon             | ⑬ Forward cabin berth                        |
| ⑤ Washroom-head                          |                      |  |



# SUN SHINE 38

TEAM AND OWNER'S VERSION

## Engine

Engine supplied (refer to price-list)  
Foam soundproofing  
Battery 70 A/H  
Access through companionway  
Access through aft cabin (Owner's version)  
Continual ventilation of engine compartment  
Exchanger for hot water (Owner's version, optional engine)  
Maximum engine power 30hp  
Illumination of engine compartment  
Water intake under engine with quarter-turn cock

Remote controls in cockpit  
Dashboard in cockpit with fuel gauge  
Dash features plexiglass cover

## Also supplied

Maintenance manual  
Hot water pipe system is installed as standard (Owner's version)

## Rigging

Anodised aluminium main mast and boom  
Double level of spreaders  
Backstay turnbuckle  
Spinnaker pole track  
Reefing winch on mast  
Clew outhaul led back to cockpit  
1 jib and mainsail halyard led back to cockpit  
Reef-band  
1 boom topping lift  
Deck floodlight  
Steaming light - Masthead light - Navigation lights on pulpit

Boom downhaul led back to cockpit  
Genoa sheets  
Mainsheet  
3 winch handles

Shroud rigging :  
1 forestay with adjuster battens  
1 inner forestay with stainless steel turnbuckle  
2 aft lower shrouds with stainless steel turnbuckles  
4 upper shrouds with stainless steel turnbuckles  
Shroud and upper shroud turnbuckles affixed to stainless steel chainplates  
Stainless steel chainplates are anchored through reinforcements onto the deck and the hull

## Sails supplied

1 mainsail  
1 genoa  
1 storm jib  
Bags

## Optional

Drop keel (refer to price-list)  
Wheel with emergency tiller (refer to price-list)  
2 x 2-speed spinnaker sheet winches  
Spinnaker pole - Spinnaker sheet - Downhaul - Topping lift - Halyard  
Spinnaker pole bell-fitting mounted on track  
Hot water tank 43 L. (9.45 imp.galls/11.36 US galls) (Owner's version)

## Construction

Yet stiffer, yet stonger, SUN-SHINE's hull is laid up by hand using startified glass KEVLAR®: l'ARAMAT K  
SUN-SHINE's interior is teak lined troughout

® Trade Mark of the Dupont de Nemours company for its high strength Aramid fibre

Jeanneau recommends **MOTUL**

Dealer's stamp

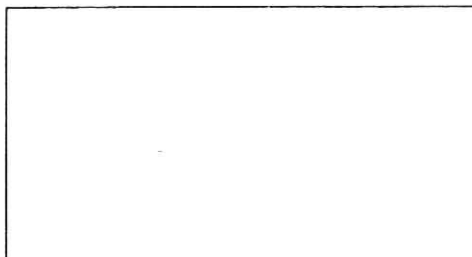

**Jeanneau**

BP 83, 85503 Les Herbiers Cedex, France. Tél. 51.91.06.10. Télex Batoja 711383 F Fax 51.67.37.65